

4x 2x

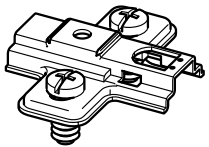

2x

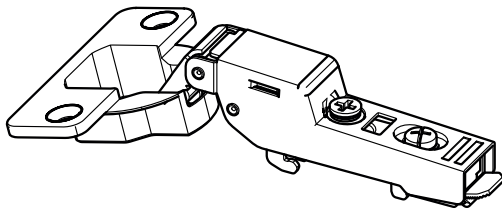

2x



1x

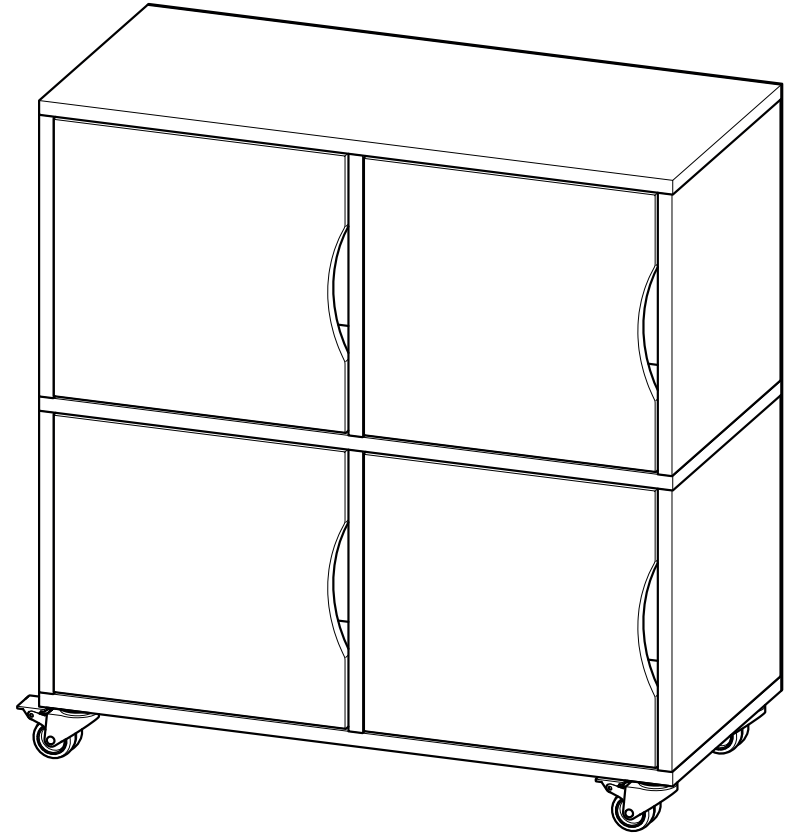

1

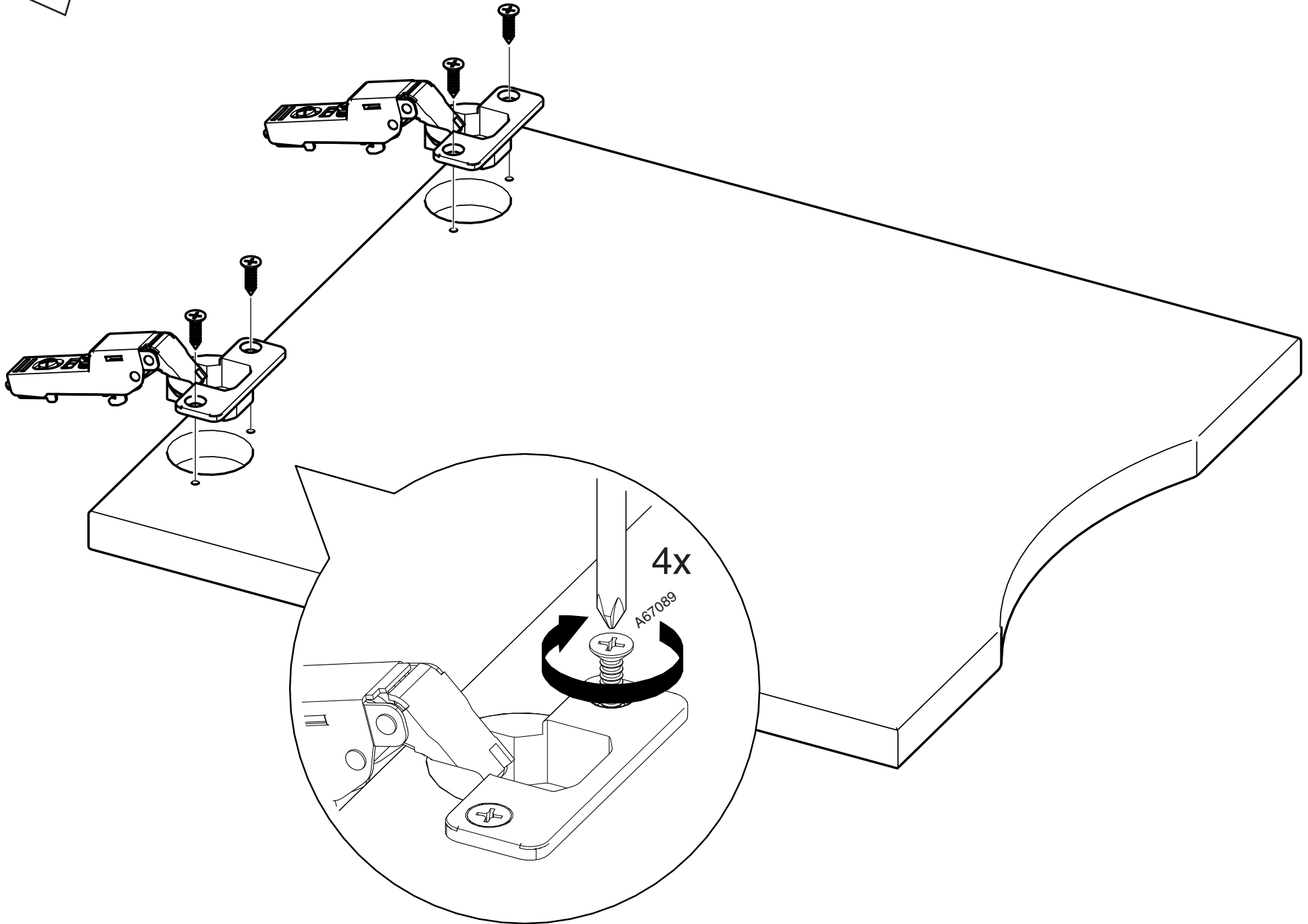

**2**

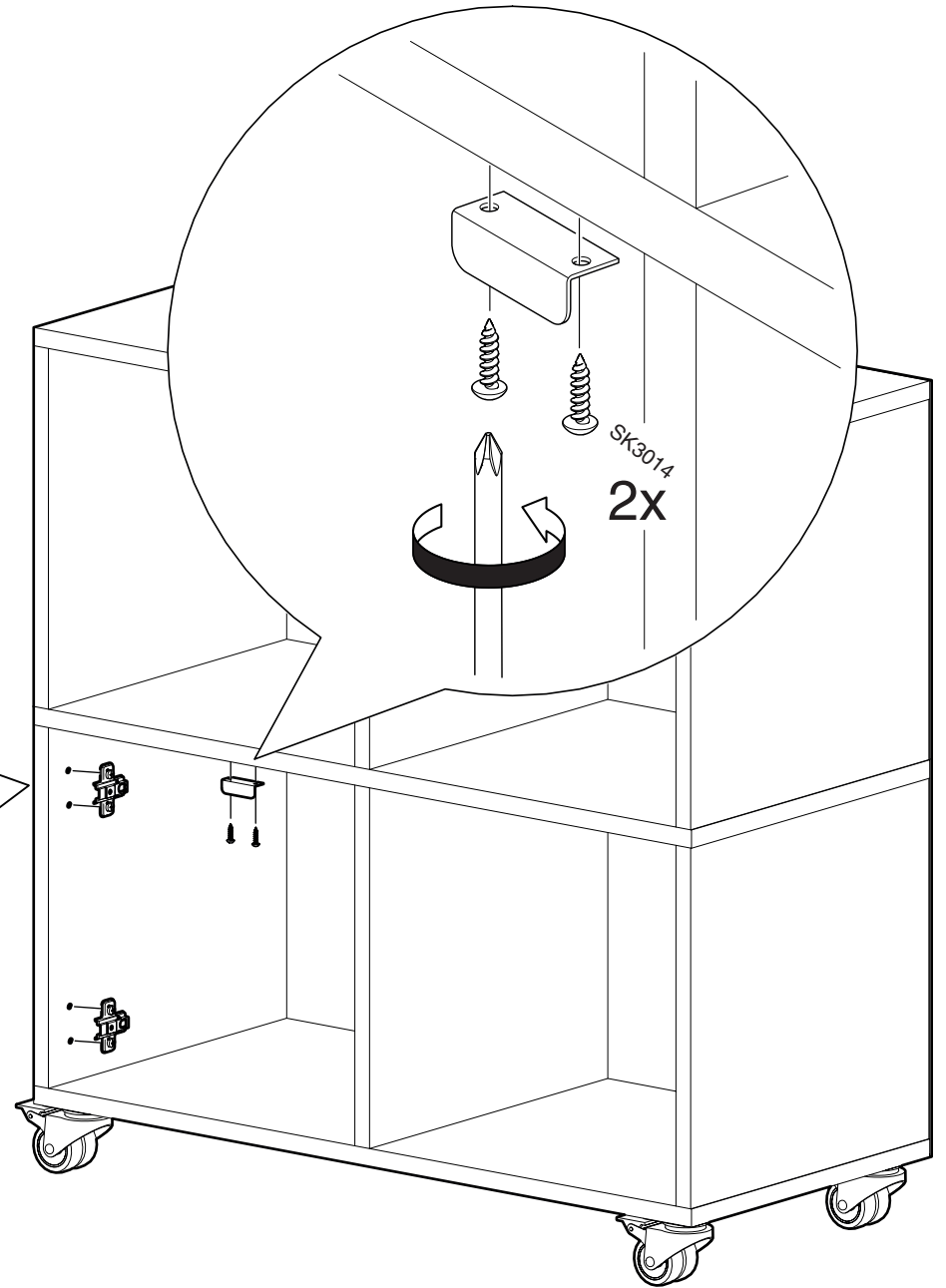
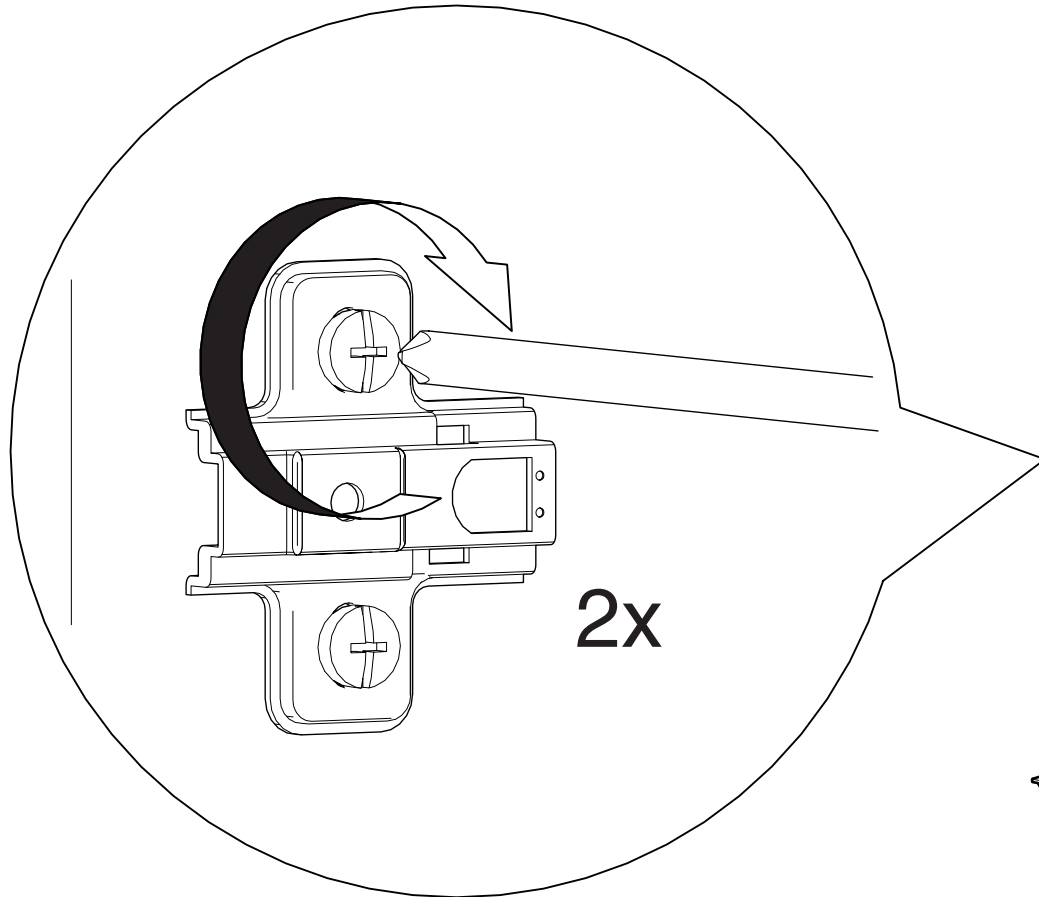

3

